



Aluminum Body

High speed & high efficiency Aluminum alloy milling tool

Aero Mill

Features

- Light Aluminum Body.
 - Weight : 50% of steel body.
 - High speed cutting, low power machine.
 - Easy handling.
- Aluminum precision cutting tool.
- Rigid body adopting high tensile aluminum.
- Locator for excellent durability.
- Tungsten carbide tool and PCD tool available.
- High rake angle : low cutting resistance.
- Balance level : G2.5



Facing



Through Coolant System



Aero Mill

Inner coolant system | Coolant bolt | Coolant cover

Aero mill

- Aero Mill, preventing overload on the axis, is suitable for all kinds of high speed machining.
- The use of insert-based and blade-based cutters allows a wider range of tooling.
- From finishing to roughing application available thanks to wide chip pocket area.
- High tensile aluminum alloy body guarantees Excellent performance.
- Chip cover protects the body from the breakage of chip action.

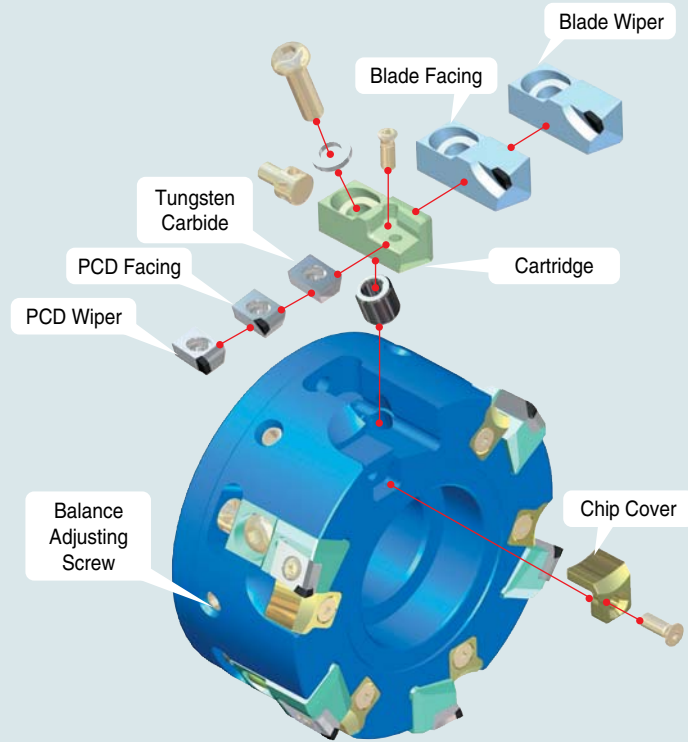

Inner coolant system

- The coolant injection is directed toward the cutting are of the insert, in order to guarantee higher chip evacuation performance and a superb cooling effect.
- Coolant bolt for under diameter 160mm, coolant cover for over diameter 200mm
 - ※ Note - Extra charge for the coolant bolt and cover.
 - Through coolant type arbor applicable only.

Coolant bolt

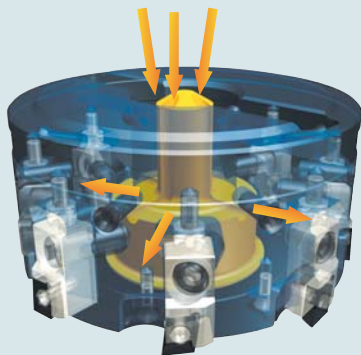

Ø 80 ~ Ø160(mm)

Coolant cover

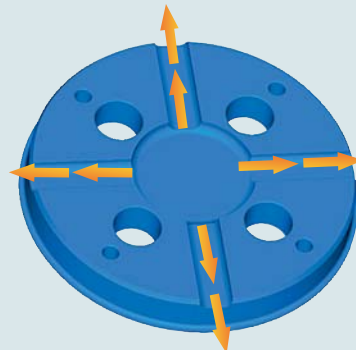

Over Ø200(mm)



Aero Mill

Application | Cutting speed | Max R.P.M. | Surface roughness

Application

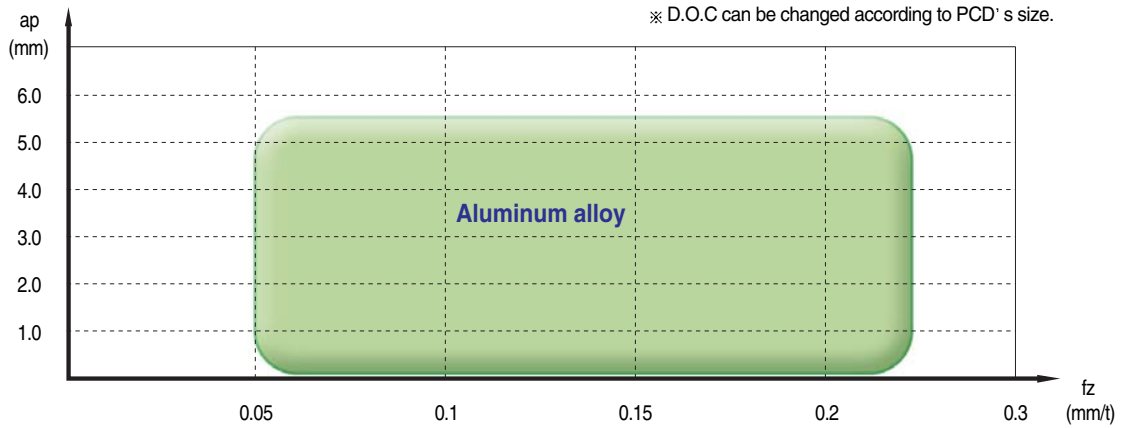

Cutting speed

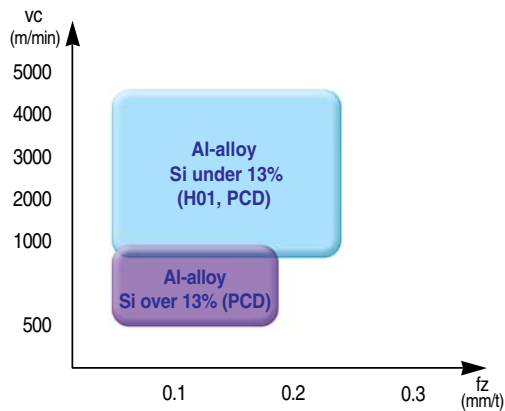

Max R.P.M.

Diameter	Max R.P.M
Ø80	16,000
Ø100	15,000
Ø125	12,500
Ø160	10,000
Ø200	8,000
Ø250	6,500
Ø315	5,000

Surface roughness

- Machine : PCV620
- Cutter : APDM100R-A6Z (6 teeth)
- n=5000 min⁻¹
- vc = 1570m/min
- Workpiece : A6061
- Insert : CDEW1204R-XCF(H01)
- vf = 3000mm/min
- fz = 0.1mm/t
- ap = 0.5mm

- Rmax : 2.1 μm
- Rz : 1.6 μm
- Ra : 0.3 μm

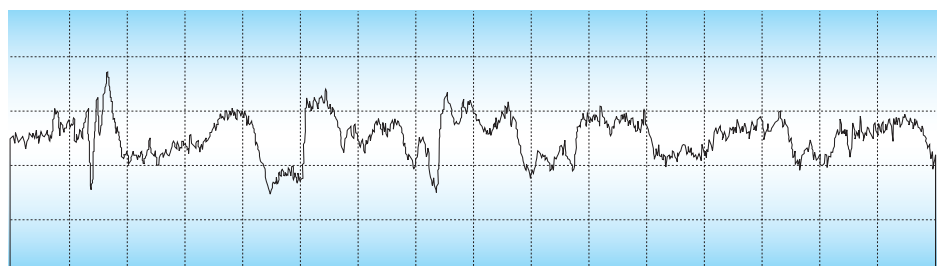

0.4 mm

4.4 mm

Aero Mill

APDM000-A Cutter | Aero Mill Code System

APDM000-A Cutter

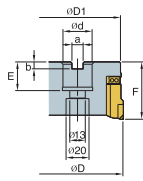

Ø80

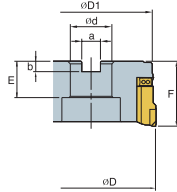

Ø100 ~ Ø160

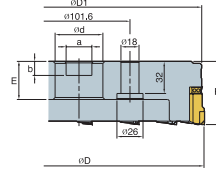

Ø200 ~ Ø250

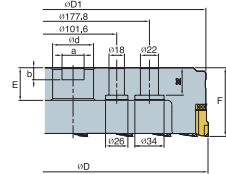

Ø315

Designation	Stock		ø D	ø D ₁	ø d	a	b	E	F	tooth	Weight (kg)
	R	L									
APDM 080R/L-A6Z	●		80	76	27	12.4	7	22	50	6	0.75
100R/L-A6Z	●		100	95	32	14.4	8	28	50	6	0.95
125R/L-A8Z	●		125	120	40	16.4	9	30	63	8	1.8
160R/L-A10Z			160	155	40	16.4	9	30	63	10	2.9
200R/L-A12Z			200	195	60	25.7	14	38	63	12	4.0
250R/L-A16Z			250	245	60	25.7	14	38	63	16	6.3
315R/L-A18Z			315	310	60	25.7	14	38	80	18	11.3

● Stock item, ○ Under preparing for stock

Aero Mill Code System

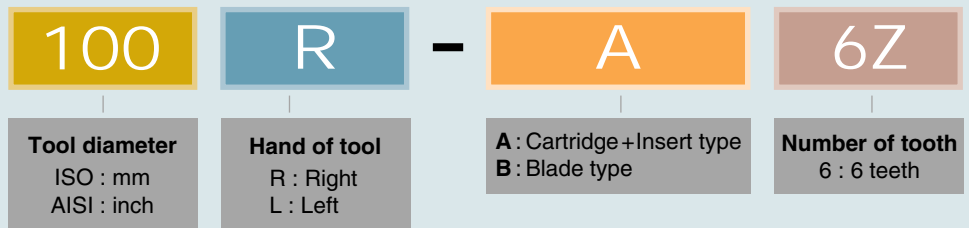
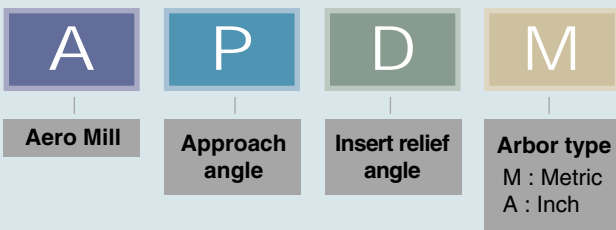

Aero Mill

APDM000-B Cutter

APDM000-B Cutter

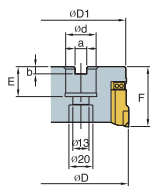

Ø 80

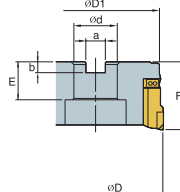

Ø100 ~ Ø160

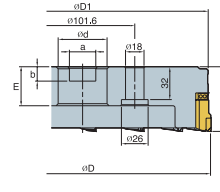

Ø 200 ~ Ø 250

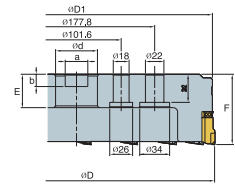

Ø 315

Designation	Stock		ϕD	ϕD_1	ϕd	a	b	E	F	tooth	Weight (kg)
	R	L									
APDM 080R/L-B6Z			80	76	27	12.4	7	22	50	6	0.75
100R/L-B6Z			100	95	32	14.4	8	28	50	6	0.95
125R/L-B8Z			125	120	40	16.4	9	30	63	8	1.8
160R/L-B10Z			160	155	40	16.4	9	30	63	10	2.9
200R/L-B12Z			200	195	60	25.7	14	38	63	12	4.0
250R/L-B16Z			250	245	60	25.7	14	38	63	16	6.3
315R/L-B18Z			315	310	60	25.7	14	38	80	18	11.3



● Stock item, ○ Under preparing for stock

Aero Mill

Insert type | Blade type | Cutting edge position

Insert type

◎ : 1st Choice ○ : 2nd Choice △ : 3rd Choice × : Bad choice

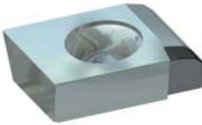

	Designation	Stock						Insert	
		H01						Finish	Rough
		R			L				
	CDEW1204R/L-XCF	●			○			△	◎
	Designation	Stock						Facing insert	
		DP150		DP200		DP2200		Finish	Rough
		R	L	R	L	R	L		
		CDEW1204R/L-XAF	○	○	●	●	○	○	◎
	CDEW1204R/L-NAF*	○	○	●	○	○	○	◎	○
	Designation	Stock						Wiper insert	
		DP150		DP200		DP2200		Finish	Rough
		R	L	R	L	R	L		
		CDEW1204R/L-XAW	○	○	●	●	○	○	◎
	CDEW1204R/L-NAW*	○	○	●	●	○	○	◎	×

※ N/L applied insert on cutting edge

● : Stock ○ : Non-Stock

Blade type

◎ : 1st Choice ○ : 2nd Choice △ : 3rd Choice × : Bad choice

	Designation	Stock			Facing insert		
		DP150	DP200	DP2200	Finish	Rough	
		BAPD(L)-XAF	○(○)	●(○)	○(○)	◎	×
	BAPD(L)-NAF*	○(○)	○(○)	○(○)	◎	○	
	Designation	Stock			Wiper insert		
		DP150	DP200	DP2200	Finish	Rough	
		BAPD(L)-XAW	○(○)	●(●)	○(○)	◎	×
		BAPD(L)-NAW*	○(○)	○(○)	○(○)	◎	×

※ N/L applied insert on cutting edge

● : Stock ○ : Non-Stock

Cutting edge position

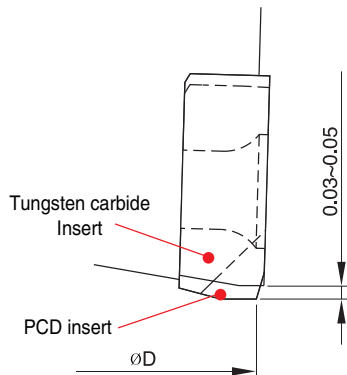

Tungsten carbide & PCD insert

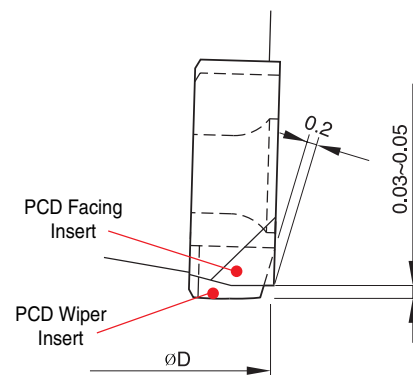









PCD facing, PCD Wiper insert

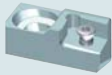



Aero Mill

Parts | Coolant parts | Safety instruction

Parts

	Cartridge	Chip Cover	Chip Cover Screw	Insert Screw	Adjust Screw	Cartridge Screw	Wrench for Insert	Wrench for Cartridge
								
APD-A	LAPDR/L-AJ	CAPDR/L-AJ	PTMA0411	FTNA0411	AZ0514	BHA0619-NYLOK	TW15S	HW50
APD-B	LAPDR/L-AJ	CAPDR/L-AJ	PTMA0411	-	AZ0514	BHA0619-NYLOK	-	HW50

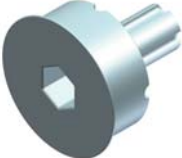
Coolant parts

Diameter	Type	Designation	Shape	Note
Ø80	COOLANT BOLT	CBP080-MM		Extra Charge
Ø100		CBP100-MM-1		
Ø125		CBP125-MM-1		
Ø160		CBP160-MM		
Ø200	COOLANT COVER	CCP200		Extra Charge
Ø250		CCP250		
Ø315		CCP315		



Warning

※ Safety instruction

- Use glasses safely and face cover with protective equipment. If cutting condition and use method are inaccurate, you may be injured by broken tools or scattered chips.
- Excessive cutting load may influence badly on both tool and machine.
Make suitable tool replacement for preventing failure of machining.
- After machine stopped, clean remained chips from machine with special cleaning equipment.
- Keep safety distance from acute and hot chip during machining.
- Make precaution for prevention of fire in advance when you use insoluble cutting oil.
- Assembled parts may be scattered at high speed cutting. Please use protective equipment.



Customer's manual

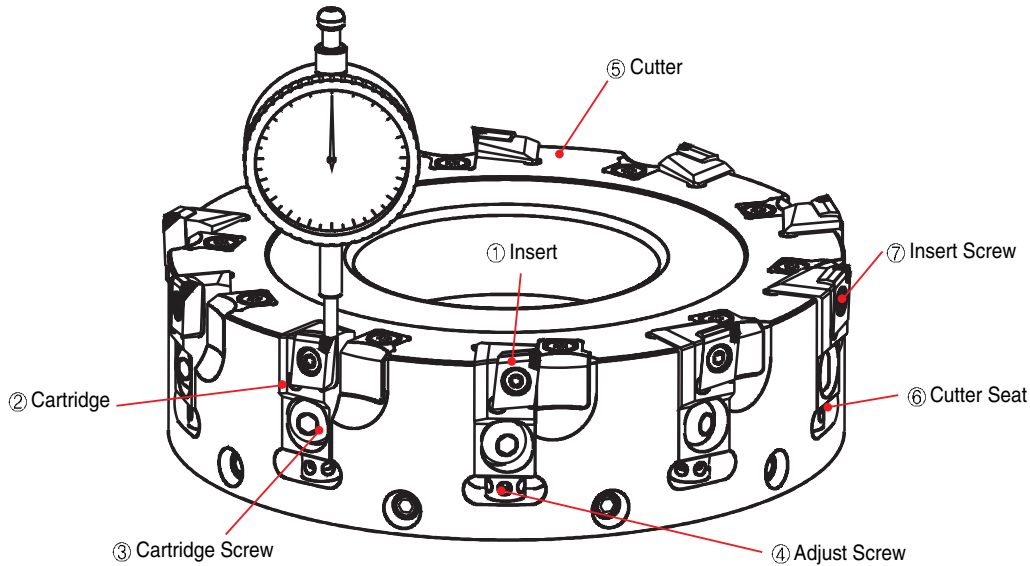

■ How to assemble the AEROMILL

1. Place ④Adjust screw in ⑥Cutter Seat.
2. Insert ②Cartridge to ④Adjust screw in ⑥Cutter Seat.
3. Insert ③Cartridge screw and joint right direction by 10Nm.
4. Place Insert on the Cartridge and joint them together by 5Nm.

■ How to adjust run-out of the AEROMILL

1. Clean the measuring instrument and set the position of the Aero mill cutter.
 2. Release ③Cartridge screw first, then joint slightly by 2Nm.
 3. Rotate the ④Adjust screw right direction and adjust it up to 5 μ m (dial gage).
 4. Joint ③Cartridge screw tightly by 10Nm.
 5. Adjust it to the zero tolerance by rotating ④Adjust screw to the right direction.
- ※ When you rotate ④Adjust screw to the right direction, inserts move to upper direction.

■ Notice

1. Please use OHP film to protect PCD insert and blade when you adjust tolerance.
It can cause chipping during adjusting run-out.
2. Please rotate the adjust screw to right direction only. When you exceed zero tolerance, should release cartridge screw first and rotate adjust screw to left direction, then rotate it to right and adjust again.